

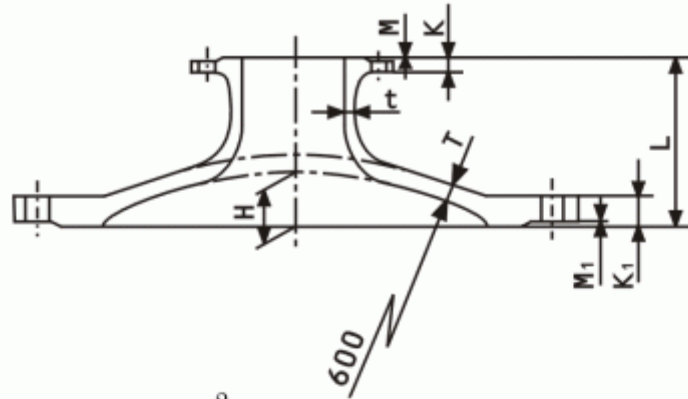

Short pipe for Fire Hydrants and Air Valves

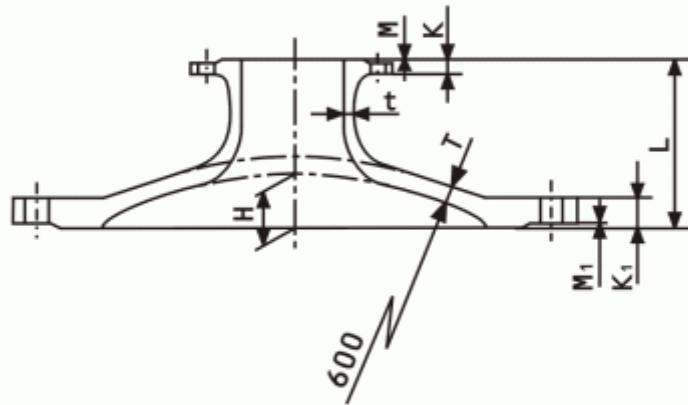

■ 7.5kgf/cm²用



■ 7.5kgf/cm²、10kgf/cm²用

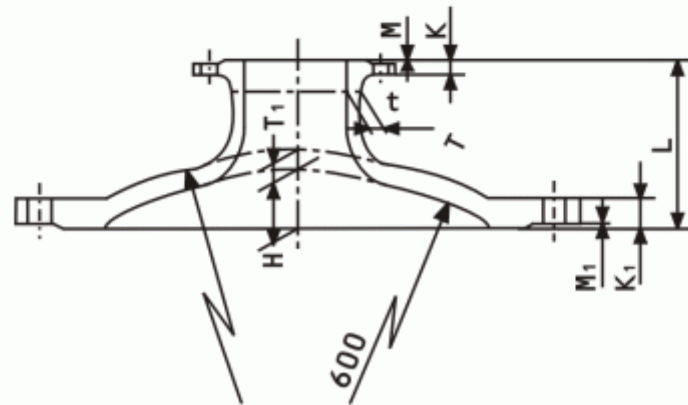

■ 16kgf/cm²、20kgf/cm²用

Unit: mm

Nom. size		Thickness			Dimensions										Weight (kg)												
D	d	T	T ₁	t	H	L	7.5 K				10 K				16 K				Type 1		Type 2						
							K	M	K ₁	M ₁	K	M	K ₁	M ₁	K	M	K ₁	M ₁	K	M	K ₁	M ₁	7.5 K	10 K	16 K	20 K	
600	75	24	38	17	81.5	240	21	3	45	4	18	2	45	3	20	2	46	3	22	2	54	3	129	129	120	174	188
600	100	24	38	17	81.5	240	21	3	45	4	18	2	45	3	22	2	46	3	24	2	54	3	130	131	121	175	189
600	150	24	38	17	81.5	240	22	3	45	4	22	2	45	3	24	2	46	3	28	2	54	3	132	132	124	177	192
600	200	24	38	17	81.5	240	23	3	45	4	22	2	45	3	26	2	46	3	30	2	54	3	133	134	125	177	192